



IL8 Series

Medium Pressure Filters



ENGINEERING YOUR SUCCESS.

IL8 Series

Applications

Applications for IL8 series filters

- Lube oil systems
- Power generation plants
- Test stands
- Primary metal equipment
- Pulp & paper equipment
- Offshore drilling and oil patch
- Flushing skids

IL8 series filters are excellent choices for your demanding applications whether you require simplex, duplex or quadplex assemblies.

Wherever high flow or high capacity filters are required, the IL8 series can be applied with confidence.

Filter housings have a simple yet critical job... securely contain the filter element with positive internal sealing.

The IL8 series filter housings are the result of careful engineering. High grade materials are used to provide strength at critical stress points.

The cover and base are anodized aluminum, the handle is nickel plated ductile iron and the bowl is rugged carbon steel. The result is a reliable high performance filter for an array of applications.

Cover

- Handle protects indicators from damage
- Easy on, easy off, for fast service

Air Bleed

- Helps protect bearings and other sensitive components from trapped air

Fill Port

- Prefilter the fluid, before it gets into the machine's system
- Purge air while filling

Indicators

- You can tell element condition at a glance
- Both visual and electrical available

Bowl

- Rugged cold drawn steel—excellent fatigue resistance
- Three sizes for any application: Single (8"), Double (16"), and Triple (39")

Ports

- SAE straight thread or flange face

Drain Port (not visible)

- Clean and easy servicing
- Lets you drain bowl of fluid before element changes

Bypass Valve (not visible)

- Soft seat design for zero internal leakage
- Located in cover assembly

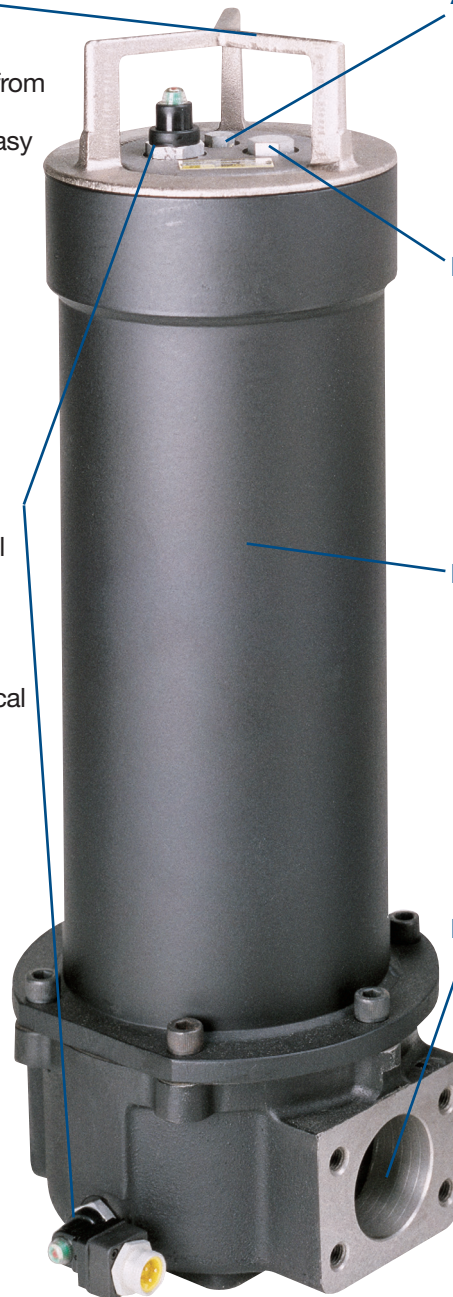

IL8 Series

Element Features

Ecoglass Replacement Elements

The latest in Ecoglass represents the merging of high performance filtration technology with environmentally conscious engineering. The Ecoglass line of replacement elements feature 100% non-metallic construction. The design reduces solid waste and minimizes disposal costs for industry. The non-metallic construction means lightweight elements (60% less weight) for easier servicing.

Ecoglass elements utilize the same proprietary media design as our Microglass line of replacement elements.

With Ecoglass, a reusable core is installed into the filter housing and remains in service throughout the life of the assembly.

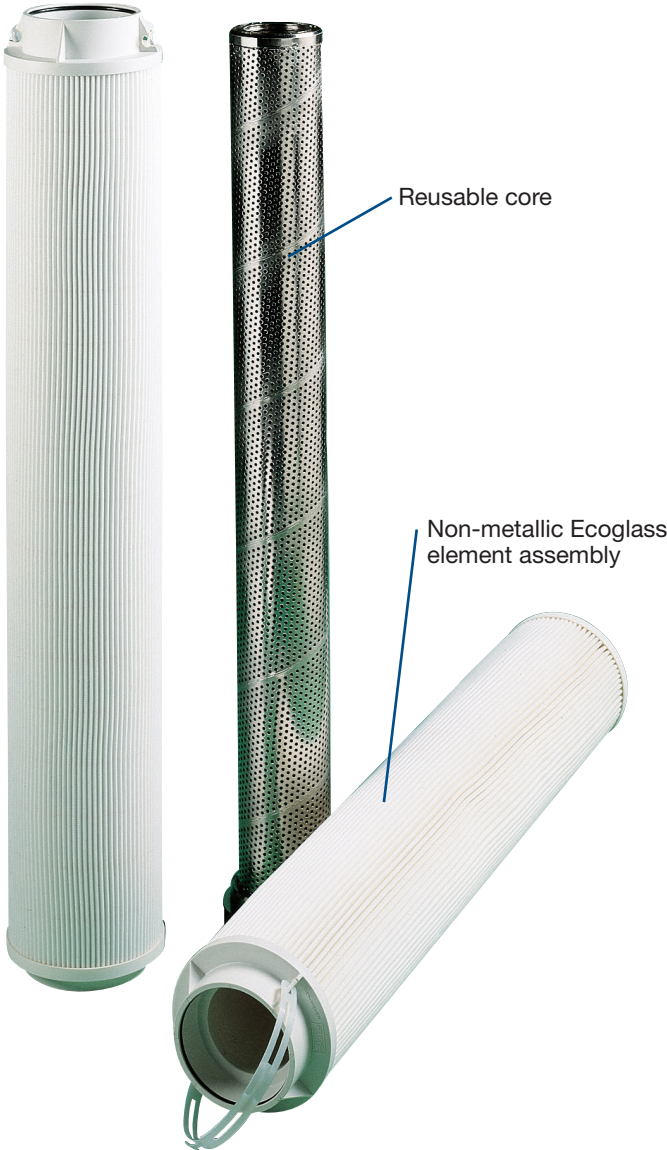

IL8 Series

IL8-2 Element Performance

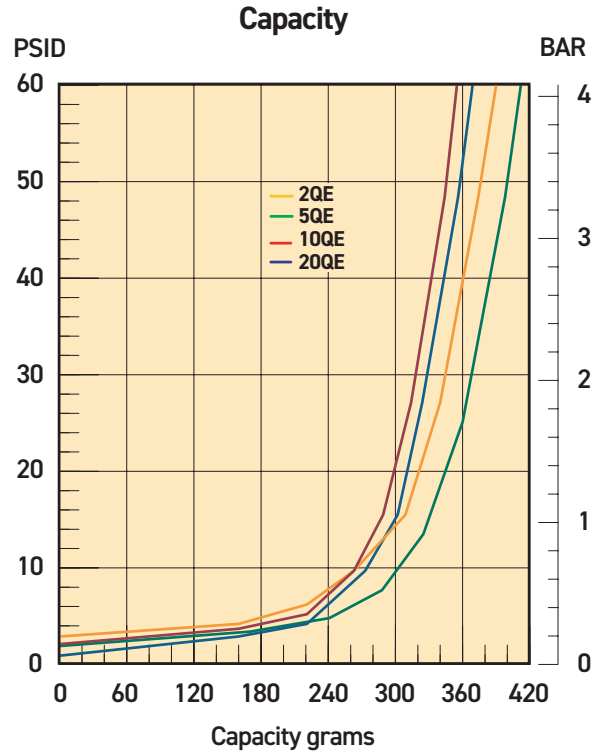
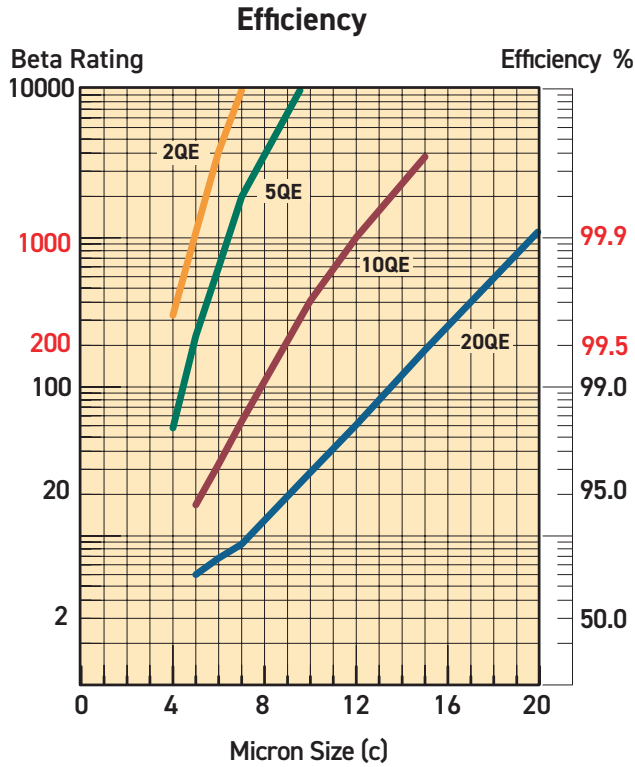

Results typical from Multi-pass tests run per test standard ISO 16889 @ 50 gpm to 60 psid terminal - 10 mg/L BUGL
Refer to Appendix for relationship to test standard ISO 4572.

Flow vs. Pressure Loss

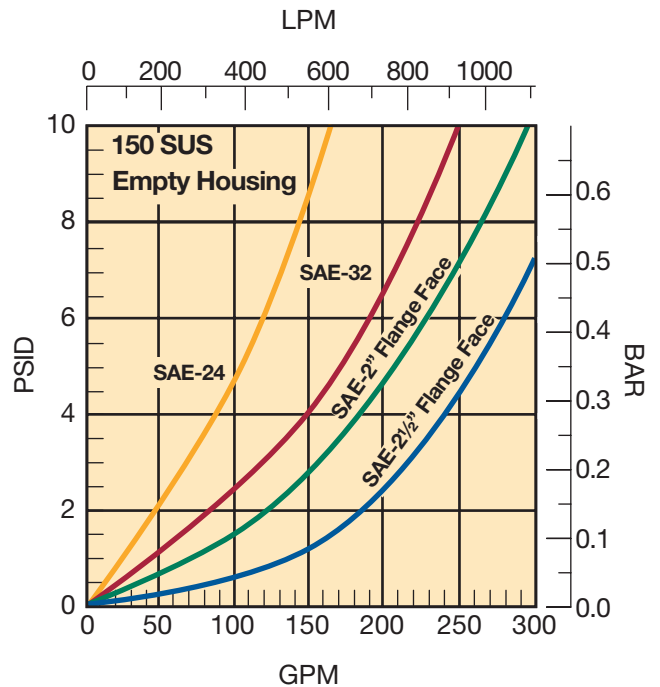
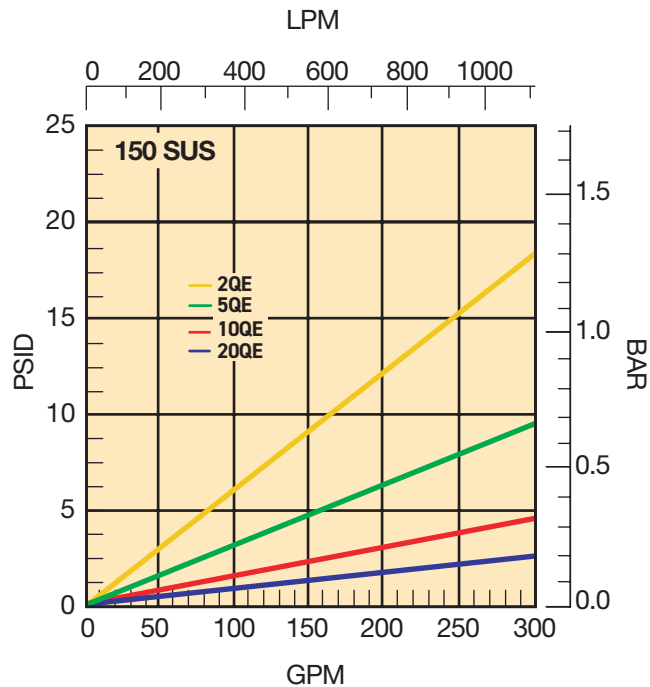

IL8 Series

IL8-3 Element Performance

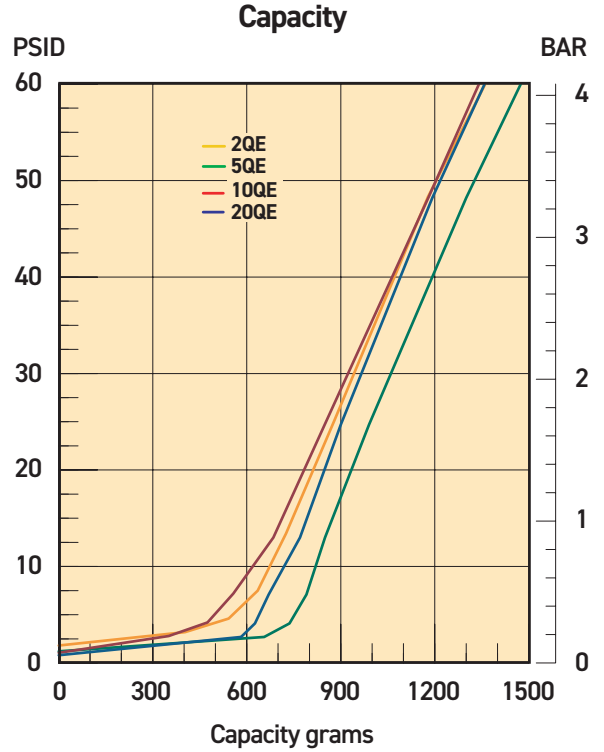
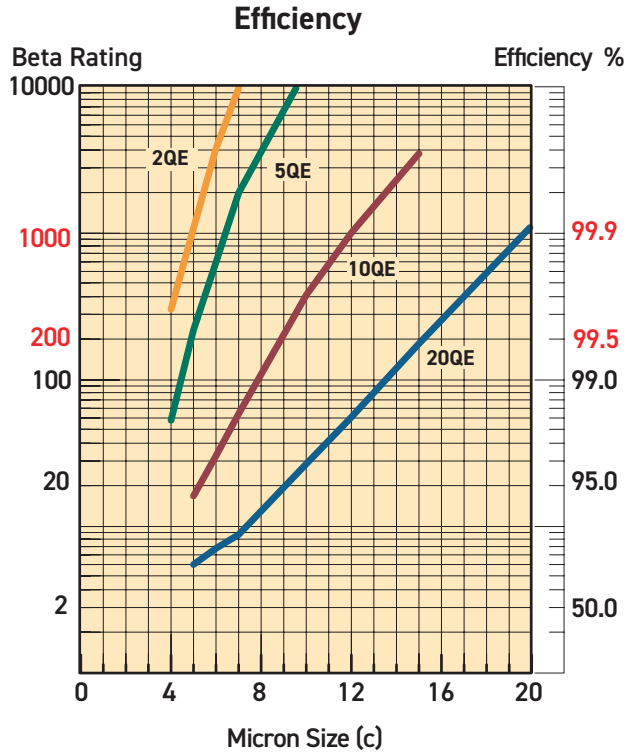

Results typical from Multi-pass tests run per test standard ISO 16889 @ 50 gpm to 60 psid terminal - 10 mg/L BUGL
Refer to Appendix for relationship to test standard ISO 4572.

Flow vs. Pressure Loss

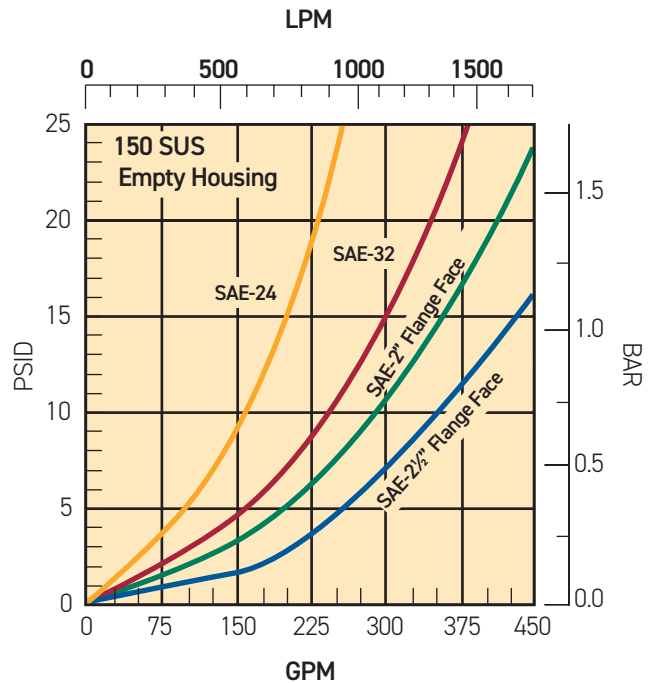
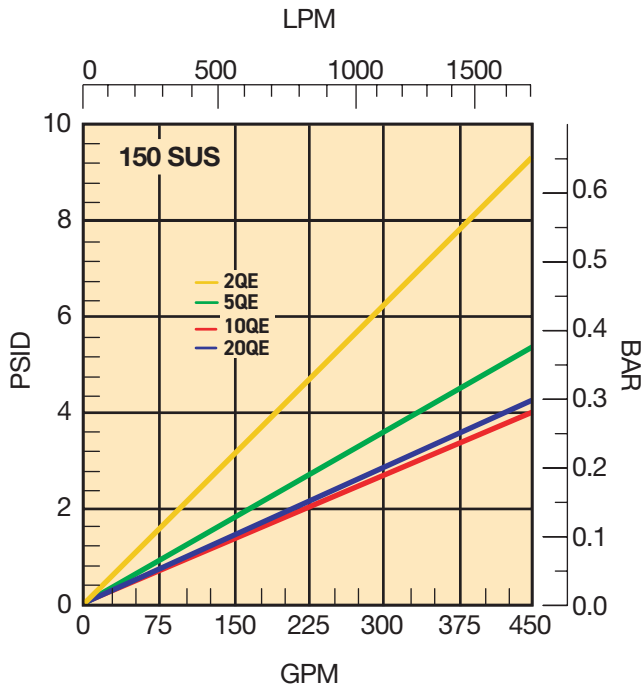

IL8 Series

Specifications: IL8

Pressure Ratings:

Maximum Allowable Operating Pressure (MAOP): 500psi (34.5 bar)
 Rated Fatigue Pressure: 330psi (22.8 bar)
 Design Safety Factor: 3:1

Operating Temperatures:

Buna: -40°F (-40°C) to 225°F (107°C)
 Fluorocarbon: -15°F (-26°C) to 275°F (135°C)

Element Collapse Rating:

150 psid (10.3 bar)

Element Condition Indicators:

Visual (optional)
 Electrical -heavy duty (optional)
 SPDT .25 amps (resistive) MAX 5
 watts 12 to 28 VDC & 110 to 175 VAC
 Note: Product of switching voltage and current
 must not exceed wattage rating

Color Coding:

White (common)
 Black (normally open)
 Blue (normally closed)

Materials:

Bowl: low carbon steel
 Cover: anodized aluminum
 Handle: nickel plated ductile iron
 Base: anodized aluminum

Shipping Weights (approximate):

Double: 50 lbs. (22.7 kg)
 Triple: 75 lbs. (34 kg)

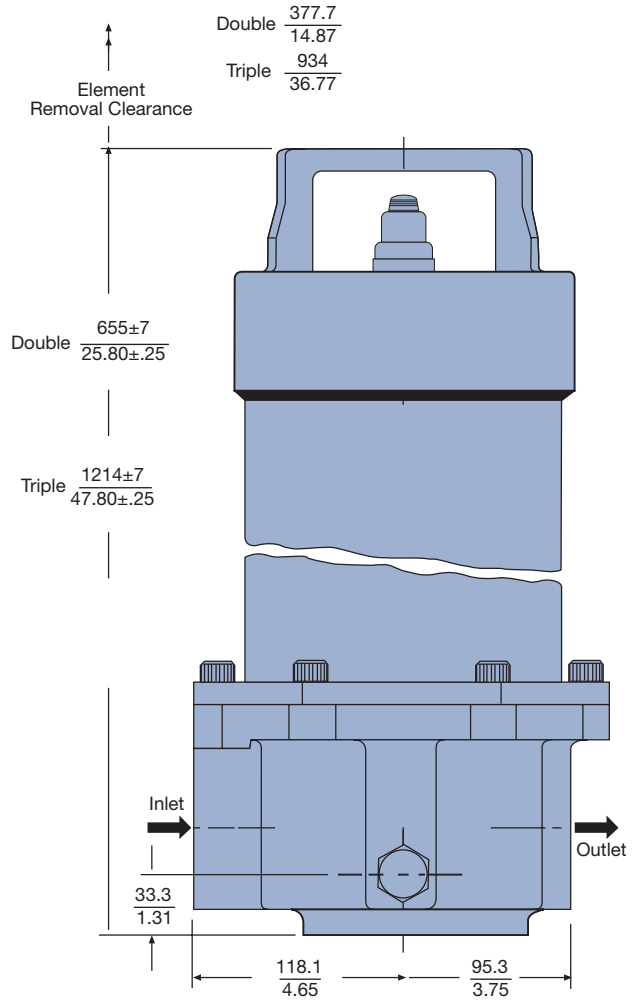

Linear Measure: millimeter
inch

Drawings are for reference only.
 Contact factory for current version.

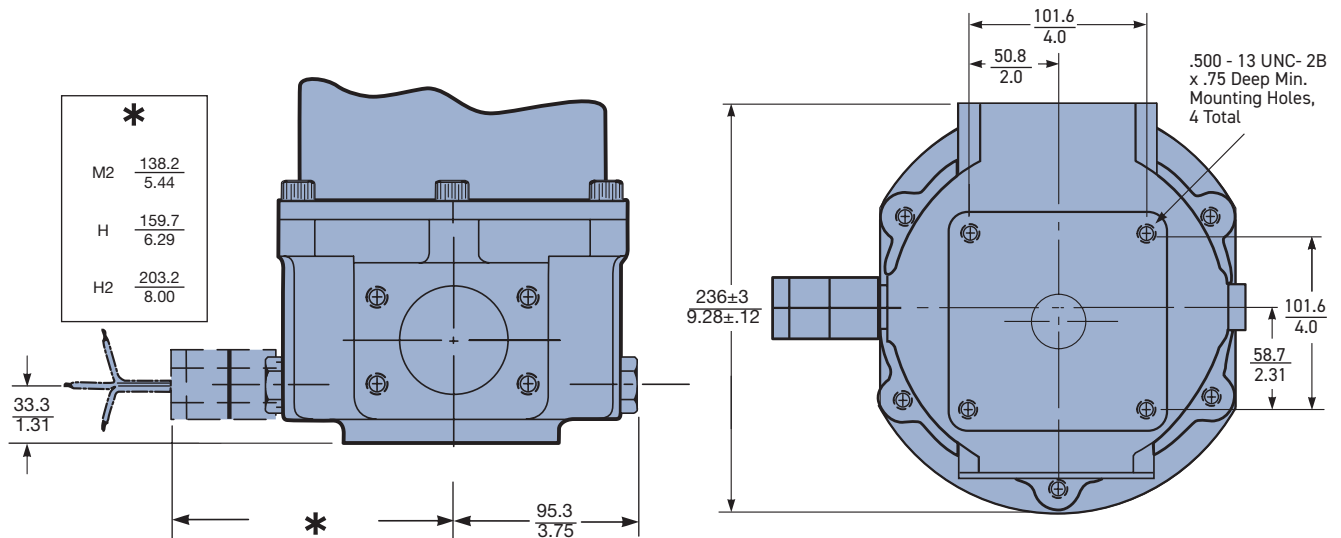

IL8 Series

Specifications: HDIL8/HQIL8

Pressure Ratings:

Maximum Allowable Operating Pressure (MAOP): 400psi (27.6 bar)
 Rated Fatigue Pressure: 330psi (22.8 bar)
 Design Safety Factor: 2.5:1

Operating Temperatures:

-15°F (-26°C) to 200°F (93°C)

Element Collapse Rating:

150 psid (10.3 bar)

Materials:

Changeover valve: steel
 Bowl: low carbon steel
 Cover: anodized aluminum
 Cover handle: nickel plated ductile iron
 Base: steel

Element Condition Indicators:

Visual (optional)
 Electrical-heavy duty (optional)
 SPDT .25 amps (resistive) MAX 5 watts
 12 to 28 VDC & 110 to 175 VAC
 Note: Product of switching voltage and current must not exceed wattage rating

Color Coding:

White (common)
 Black (normally open)
 Blue (normally closed)

Shipping Weights (approximate):

HDIL8-2	320 lbs. (145 kg)
HDIL8-3	375 lbs. (170 kg)
HQIL8-2	525 lbs. (238 kg)
HQIL8-3	650 lbs. (295 kg)

ANSI Flange Adapter

End, Side View

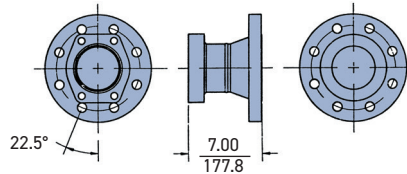

Linear Measure: $\frac{\text{millimeter}}{\text{inch}}$

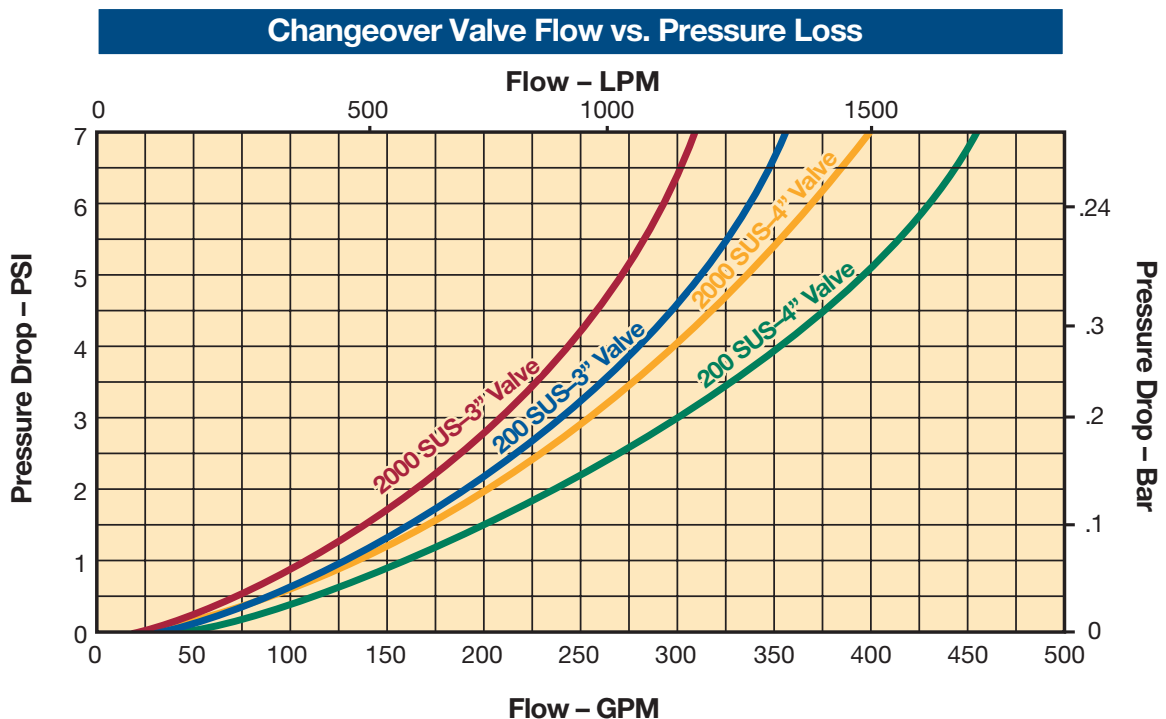

IL8 Series

Specifications: HDIL8/HQIL8

Linear Measure: millimeter
inch

HDIL8
Top View

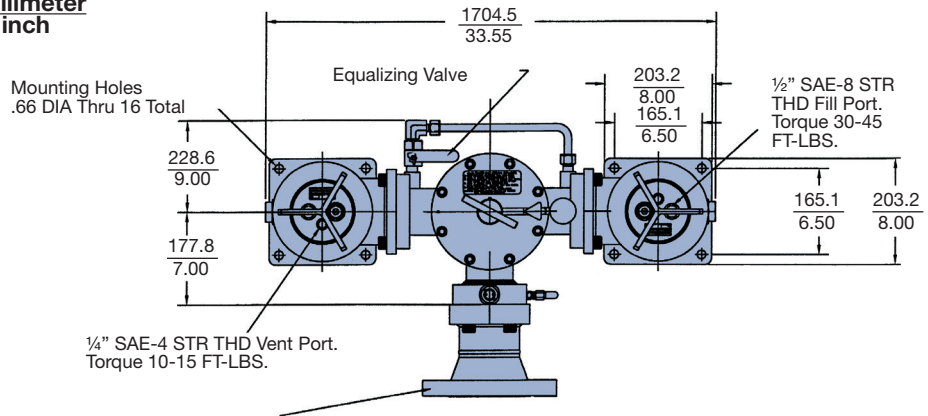

HDIL8/HQIL8
Side View

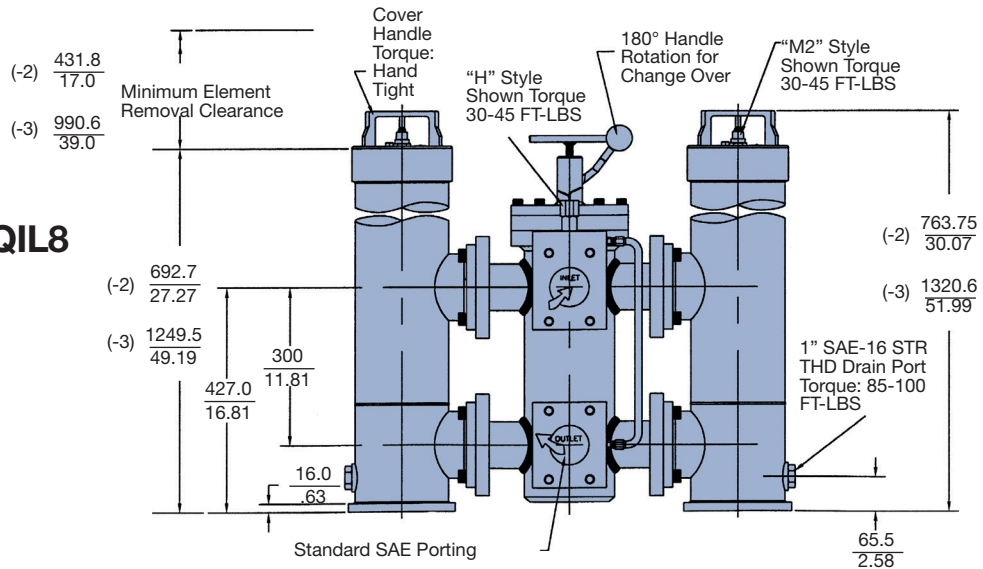

HQIL8
Top View

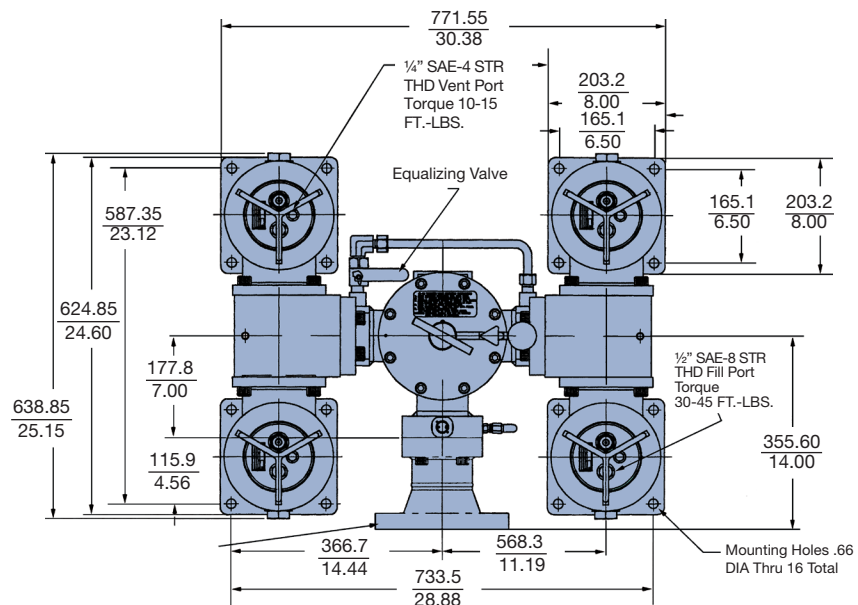

Drawings are for reference only.
Contact factory for current version.

IL8 Series

Element Servicing Instructions: IL8

When servicing the IL8 filter, use the following procedure:

1. Stop the system's power unit.
2. Relieve pressure in the filter line. Drain fluid from housing if desired.
3. Rotate cover handle counter-clock wise. Carefully lift and remove the cover.
4. Remove element from the housing. Discard all disposable elements as they are not cleanable. With Ecoglass elements the permanent core will remain in the housing.
5. Place new element in housing, centering it on the element locator in the bottom of bowl.
6. Inspect cover o-ring and replace if necessary.
7. Install cover, rotate clockwise and hand tighten.

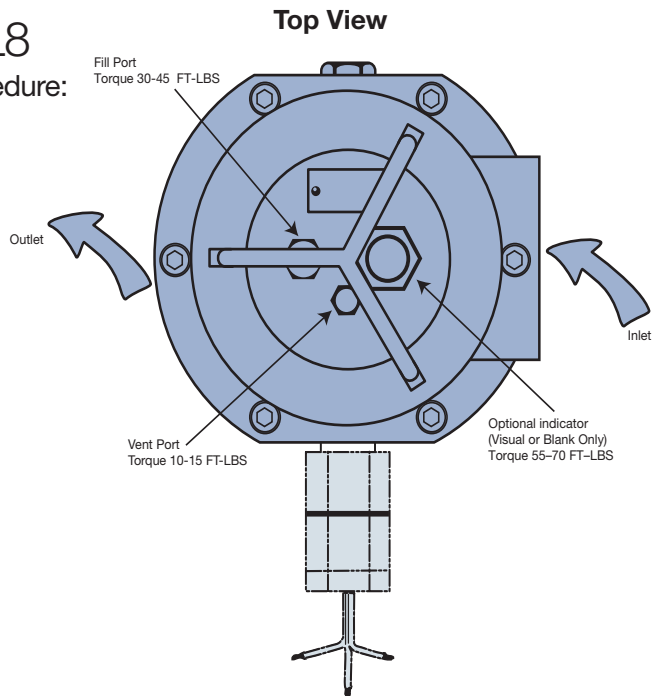

Parts List

Index	Description	Nitrile P/N	Fluorocarbon P/N
1	Cover Assembly		
	25 psi bypass w/indicator port	928887	928888
	50 psi bypass w/indicator port	928889	928890
	No bypass w/indicator port	928891	928892
2	Cover o-ring	N72257	V72257
3	Indicators		
	P option-indicator port plug	N/A	925515
	M2 25 PSI	N/A	932026
	M2 50 PSI	N/A	932027
	H 25 PSI	N/A	933053
	H 50 PSI	N/A	932905
	H2 25 PSI	N/A	933141
H2 50 PSI	N/A	933142	
4	Elements (See chart on model code page)		
not shown	Bleed (vent) Plug , SAE 4	931357	931358
6	Fill Plug , SAE 8	908822	928628
not shown	Drain Port Plug , SAE 10	925513	928883
7	Base O-ring	N72262	V72262
	Flange Kits (optional)		
	1 1/2" NPTF (w/2" flange face only)	924786	926011
	2" NPTF (w/2" flange face only)	924785	926010
	SAE-24 (w/2" flange face only)	924782	926007

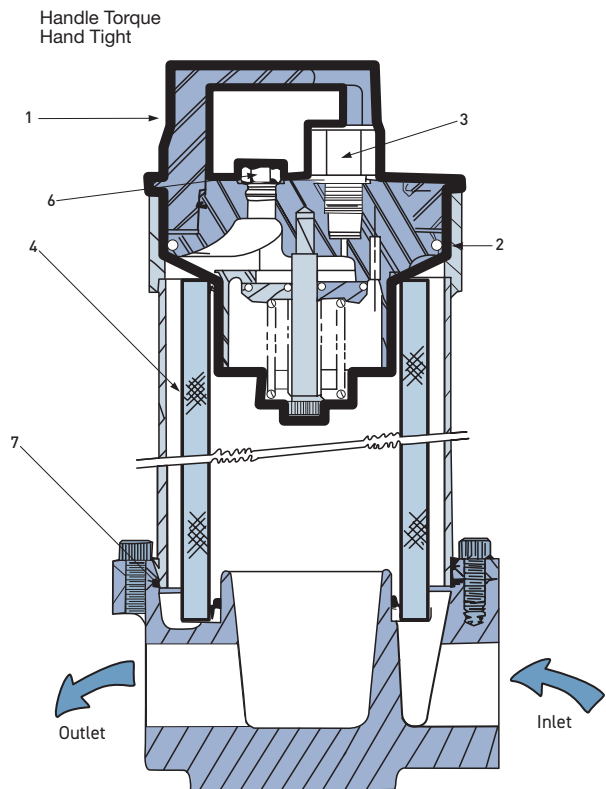

Drawings are for reference only.
Contact factory for current version.

IL8 Series

Element Servicing Instructions: HDIL8/HQIL8

The system does not need to be shut down to service the elements.

1. Red arrow on operating handle points to on-duty chamber(s).
2. Open off-duty vent plug(s). Do not thread out completely.
3. Open the pressure equalizing (fill line) valve slowly to admit fluid to the off-duty chamber(s).
4. When fluid is discharged from the off-duty vent plug(s), close and tighten.
5. Turn the “T” handle, on the center valve section, counter-clockwise 5 turns.
6. Depress the operating handle to unseat the seal shoes, then rotate 180° and return handle upward into the opposite slot.
7. Turn the “T” handle fully clockwise and hand tighten only. This will seat the shoes.
8. Close the pressure equalizing valve.
9. Red arrow now points to the new on-duty chamber(s).
10. Open the new off-duty vent plug(s).
11. Remove the new off-duty chamber cover(s) by rotating counter-clockwise.
12. Remove the new off-duty drain plugs and drain chambers to desired level.
13. Follow steps 3 - 7 on opposite page.
14. Close and tighten the vent plug(s).

Warning: You should not rotate the handle until you equalize the pressure.

Parts List

Index	Description	HDIL8		HQIL8	
		Nitrile	Fluorocarbon	Nitrile	Fluorocarbon
1	Cover Assembly				
	25psi bypass w/indicator port	928887	928888	928887	928888
	50psi bypass w/indicator port	928889	928890	928889	928890
	No bypass w/indicator port	928891	928892	928891	928892
2	Cover O-ring	N72257	V72257	N72257	V72257
3	Indicators				
	P option-indicator port plug	N/A	925515	N/A	925515
	M2 25psi	N/A	932026	N/A	932026
	M2 50psi	N/A	932027	N/A	932027
	H 25psi	N/A	933053	N/A	933053
	H 50psi	N/A	932905	N/A	932905
	H2 25psi	N/A	933141	N/A	933141
	H2 50psi	N/A	933142	N/A	933142
4	Elements (see chart on model code page)				
5	Bleed (vent) Plug, SAE-4	931357	931358	931357	931358
6	Fill Plug, SAE-8	908822	928628	908822	928628
7	Drain Plug SAE-16	925353	928364	925353	928364
8	Transfer Valve				
	SAE 4" SAE 3"	933824 933825	936123 936122	933824 933825	936123 936122
9	Housing Assembly				
	Double length Triple length	933832 933831	933832 933831	933832 933831	933832 933831
10	5/8"-11 x 3" SHCS	933928	933928	933928	933928
11	5/8" Lock Washer	933879	933879	933879	933879
12	Adapter Block Kit (block, 3 o-rings, 12 bolts)	N/A	N/A	N/A	933833
13	Seal Kit Transfer Valve		935409		936346

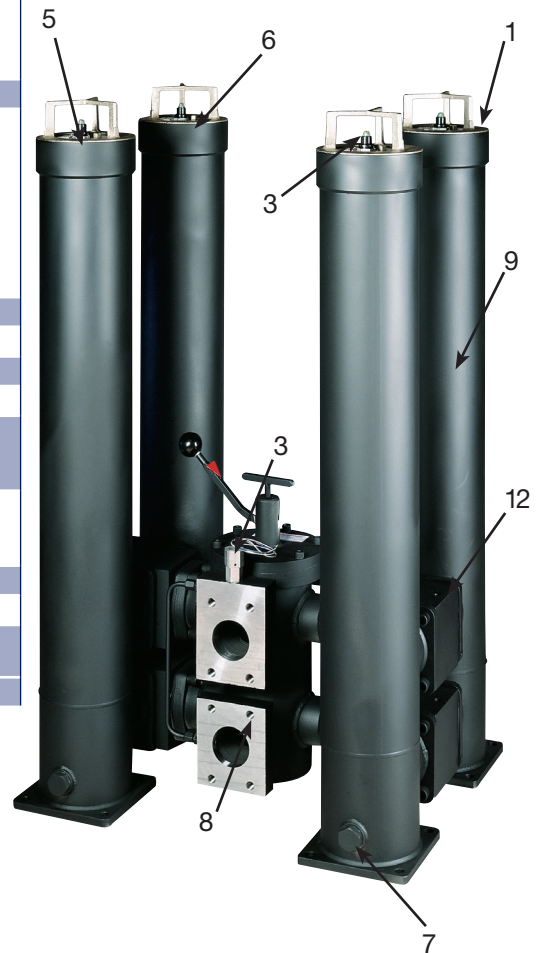

IL8 Series

Medium Pressure Filters

How To Order

Select the desired symbol (in the correct position) to construct a model code. Example:

BOX 1	BOX 2	BOX 3	BOX 4	BOX 5	BOX 6	BOX 7	BOX 8	BOX 9
	IL8	2	R	20QE	HM2	25	QQ	1

BOX 1: Seals	
Symbols	Description
None	Nitrile
F3	Fluorocarbon

BOX 2: Filter Series	
Symbols	Description
IL8	In-Line

BOX 3: Length	
Symbols	Description
2	Double
3	Triple

BOX 4: Core	
Symbols	Description
R	Reusable

BOX 5: Media Code	
Symbols	Description
02QE	Ecoglass, 2 micron
05QE	Ecoglass, 5 micron
10QE	Ecoglass, 10 micron
20QE	Ecoglass, 20 micron

BOX 6: Indicators	
Symbols	Description
Base Indicator Options	
P	No pressure port indicator, port only
M2	Visual auto reset
H	Electrical w/ conduit connection
H2	Electrical w/ DIN 43650 connection
Cover Indicator Options	
P	No pressure port indicator, port only
M2	Visual auto reset

BOX 7: Bypass	
Symbols	Description
25	25 psid (1.7 bar)
50	50 psid (3.5 bar)
XX	No indicator and blocked bypass

BOX 8: Ports	
Symbols	Description
PP	SAE-24 straight thread
RR	SAE-32 straight thread
YY	SAE 2" flange face
ZZ*	SAE 2-1/2" flange face

BOX 8: Options	
Symbol	Description
1	None
11	Blocked bypass

Replacement Elements

Media	Double	Triple
02QE	933834Q	933734Q
05QE	933835Q	933612Q
10QE	933836Q	933735Q
20QE	933837Q	933736Q
Reusable Core	933838	933636

